HIGAIN TEST CARD

MODEL HTC-388

List Number

Part Number

1

150-1285-01

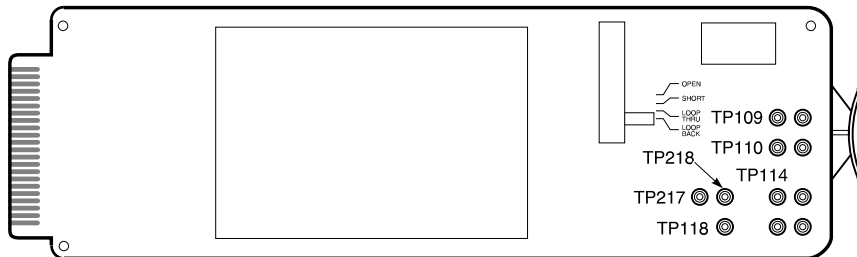

PAIRGAIN TECHNOLOGIES, INC.
ENGINEERING SERVICES TECHNICAL PRACTICE
SECTION 100-388-100

Revision History of this practice.

Revision 01—October 18, 1996

A) Initial release

*©Copyright 1996 PairGain Technologies, Inc.
PairGain is a registered trademark, and HiGain is a trademark of PairGain Technologies, Inc.*

TABLE OF CONTENTS

A. PRODUCT OVERVIEW.....	1
1. Description and Features.....	1
2. Application	1
3. Specifications.....	1
B. FUNCTIONAL DESCRIPTION	2
4. Test Capabilities	2
5. Unpacking and Inspection	2
C. OPERATION.....	4
6. Installation and Test.....	4
D. TECHNICAL ASSISTANCE AND WARRANTY	6
7. Finding Technical Assistance.....	6
8. Warranty	6

USING THIS TECHNICAL PRACTICE

Three types of messages, identified by icons, appear in the text:



A note informs you of special circumstances.



A caution warns you of possible damage to equipment.



A warning indicates the possibility of personal injury.

A. PRODUCT OVERVIEW

1. Description and Features

1.1 The PairGain® HTC-388 Test Card, List 1, provides you with an easy method of testing Central Office (CO) and Field Tip and Ring transmit and receive pairs. A four-position slide switch lets you select the type of test you wish to perform while test points and miniature 210 jacks provide access to the circuits under test. The HTC-388 card extends beyond the front plane of the shelf or enclosure into which it is inserted. This permits easy access to the test points.

1.2 HTC-388, List 1, features:

- Switch selectable loopback, loop-through, short, and open testing of XMT (transmit) and RCV (receive) Tip and Ring pairs on CO and Field circuits.
- Test point access to Tip and Ring XMT and RCV circuits (CO and Field), circuit ground, frame ground, and -48V power.
- Miniature 210 jacks, located in the J1 block, allow access to both CO and Field sides.

2. Application

2.1 The primary application of the HTC-388 Test Card is to provide test access to the CO and Field circuits of HiGain™ HLU-388 line units.

3. Specifications

Mechanical Specifications

Mounting: ----- Plugs into any DDM+ mechanics shelf slot
 Operating Temperature:-----40° to +149° F (-40° to +65° C)
 Operating Humidity: -----5% to 95% (non condensing)

Dimensions

Height:----- 3.5 in. (8.89 cm)
 Width: -----0.6 in. (1.52 cm)
 Depth:----- 13.0 in. (33.02 cm)
 Weight: ----- 1.25 lbs (0.57 kg)

B. FUNCTIONAL DESCRIPTION

4. Test Capabilities

4.1 Test points on the Test Card provide access to each circuit under test as well as to circuit ground, frame ground, and, if available, -48V. The number of each test point corresponds to the edge connector pin of the circuit under test. See Figure 1.



A 47-kOhm resistor connected between the -48V source and the test point limits current in case of accidental shorting.

4.2 The HTC-388 Test Card enables you to perform LOOP-BACK, LOOP-THRU, SHORT, and OPEN tests on CO and Field circuits by using the four-position test selection switch (S1) to select the appropriate test. All tests are run on both side 1 and side 2. Figure 1 illustrates the locations of the test points, 210 jacks, and selector switch. Figure 2 illustrates the connection of Tip and Ring pairs of CO and Field circuits for each setting of the test switch. Table 2 lists the circuit and pin connections during the tests.

4.3 Two miniature 210 jacks allow both CO and Field sides to be accessed. They provide monitor access in switch position LOOP BACK and LOOP THRU. The OPEN switch position effectively provides a splitting-type access to one pair of the CO and Field sides and the 210 jacks. This allows you to check each side of the circuit separately.

5. Unpacking and Inspection

5.1 Upon receipt of the card, visually inspect the packaging for signs of damage.

5.2 After removing the packaging, visually inspect the card for signs of damage.

5.3 If the card has been damaged in transit, immediately report the extent of damage to the transportation company and to PairGain.

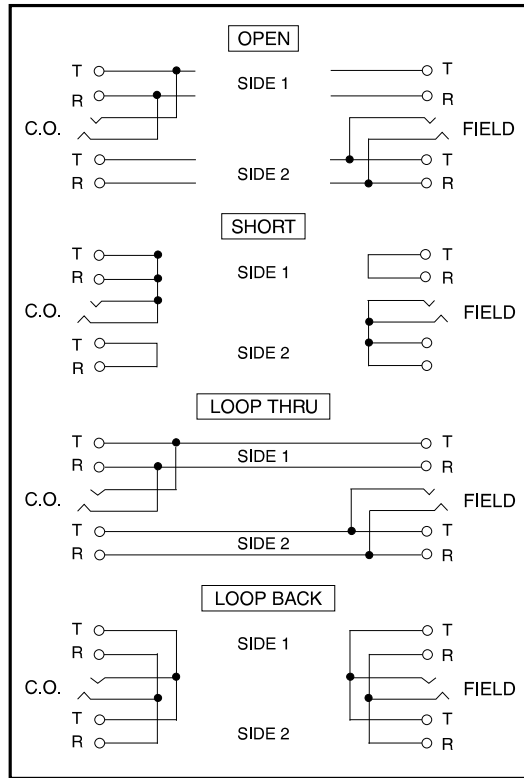
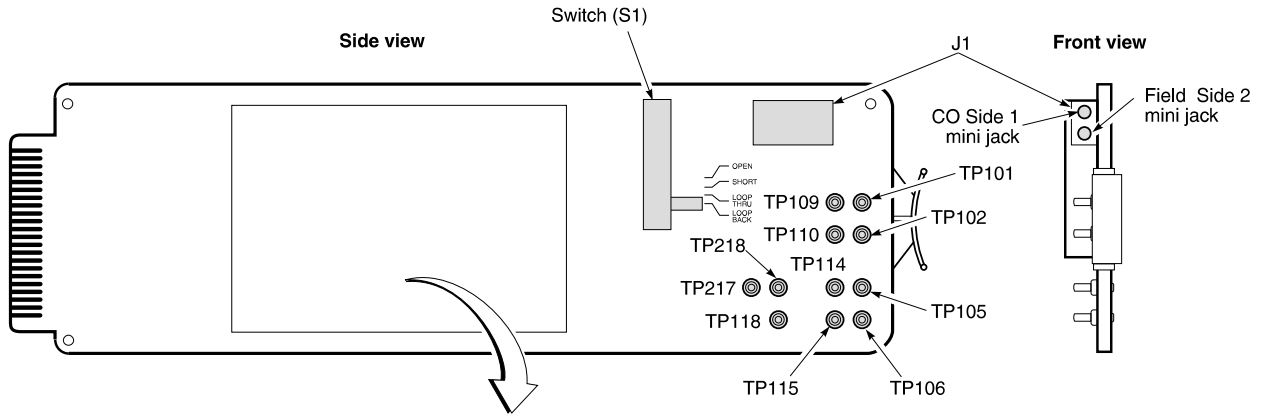

Figure 1. HTC-388 Test Card, List 1

C. OPERATION

6. Installation and Test

6.1 Use the HTC-388 Test Card to test circuits:

- 1 Plug the Test Card into the shelf slot whose circuits you want to test.
- 2 Set switch S1 on the card to the type of test you want to perform (LOOP BACK, LOOP THRU, SHORT, or OPEN). Figure 2 and Table 1 illustrate and list the connection of Tip and Ring pairs of CO and Field circuits for each setting of the test switch (S1). Pin numbers correspond to edge connector pins for each circuit.
- 3 Perform the selected test. Monitor the circuits at the corresponding test points on the card.
- 4 Repeat steps 2 and 3 as required.

Table 1. Test Connections

LOOP-BACK - This switch position connects the following circuits:				
CO Tip	Pin # 109	TO	CO Tip	Pin # 114
CO Ring	Pin # 110	TO	CO Ring	Pin # 115
Field Tip	Pin # 101	TO	Field Tip	Pin # 105
Field Ring	Pin # 102	TO	Field Ring	Pin # 106
LOOP-THRU - This switch position connects the following circuits:				
CO Tip	Pin # 109	TO	Field Tip	Pin # 101
CO Ring	Pin # 110	TO	Field Ring	Pin # 102
CO Tip	Pin # 114	TO	Field Tip	Pin # 105
CO Ring	Pin # 115	TO	Field Ring	Pin # 106
SHORT - This switch position connects the following circuits:				
CO Tip	Pin # 109	TO	CO Ring	Pin # 110
CO Tip	Pin # 114	TO	CO Ring	Pin # 115
Field Tip	Pin # 101	TO	Field Ring	Pin # 102
Field Tip	Pin # 105	TO	Field Ring	Pin # 106
OPEN - This switch position removes all connection between the circuits.				

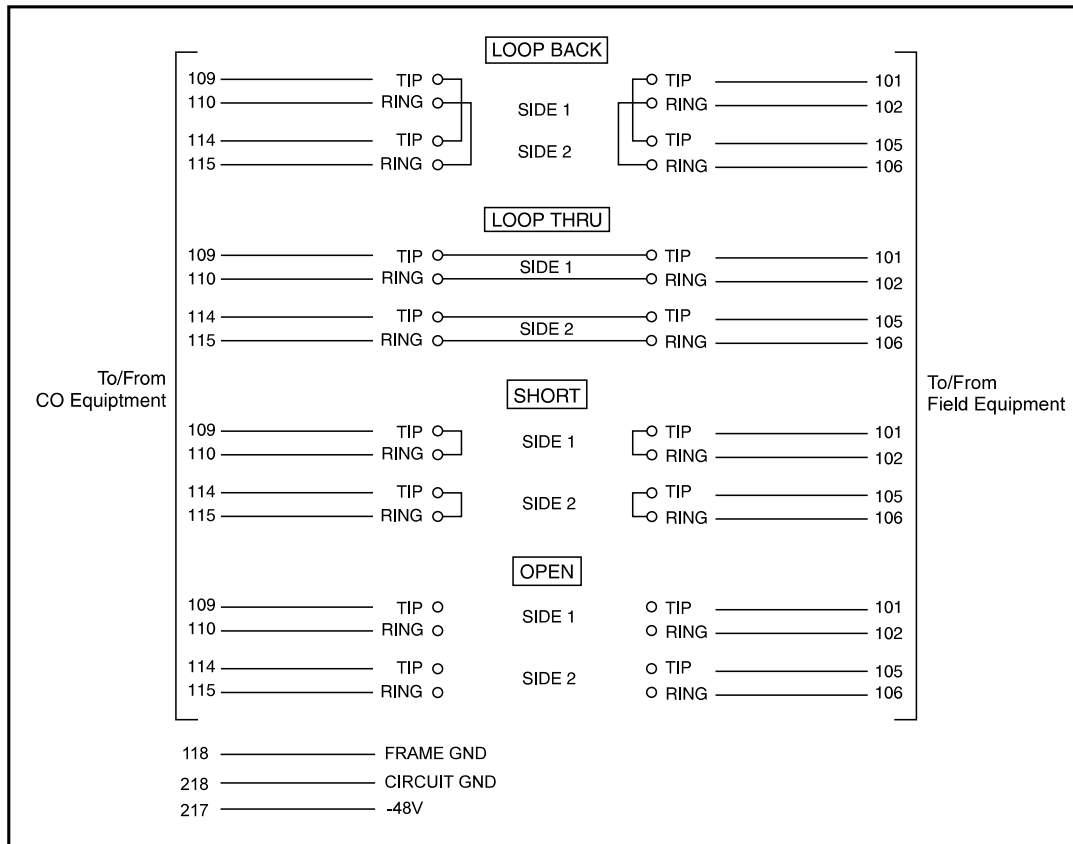

Figure 2. HTC-388 Test Card Test Connections.

D. TECHNICAL ASSISTANCE AND WARRANTY

7. Finding Technical Assistance

7.1 PairGain Technical Assistance is available 24-hours-a-day, 7-days-a-week by contacting PairGain Customer Service Engineering group at:

Telephone: (800) 638-0031 or (714) 832-9922

Fax: (714) 832-9924

7.2 During normal business hours (8:00 AM to 5:00 PM, Pacific Time, Monday - Friday, excluding holidays), technical assistance calls are normally answered directly by a Customer Service Engineer. At other times, a request for technical assistance is handled by an on-duty Customer Service Engineer through a callback process. This process normally results in a callback within 30 minutes of initiating the request.

7.3 In addition, PairGain maintains a computer bulletin board system for obtaining current information on PairGain products, product troubleshooting tips and aids, accessing helpful utilities, and for posting requests or questions. This system is available 24-hours-a-day by calling (714) 730-3299. Transmission speeds up to 28.8 kbps are supported with a character format of 8-N-1.

8. Warranty

8.1 PairGain Technologies warrants this product to be free of defects and to be fully functional for a period of 60 months from the date of original shipment, given proper customer installation and regular maintenance. PairGain will repair or replace any unit without cost during this period if the unit is found to be defective for any reason other than abuse or improper use or installation.

8.2 Do not try to repair the unit. If it fails, replace it with another unit and return the faulty unit to PairGain for repair. Any modifications of the unit by anyone other than an authorized PairGain representative voids the warranty.

8.3 If a unit needs repair:

1. Call PairGain for a Return Material Authorization (RMA) number at (800) 638-0031.
2. Return the defective unit, freight prepaid, along with a brief description of the problem, to:

PairGain Technologies, Inc.
2120 Ritchey Street
Santa Ana, CA 92705-5101
ATTN: Repair and Return Dept.

8.4 PairGain continues to repair faulty modules beyond the warranty program at a nominal charge. Contact your PairGain sales representative for details and pricing.

Corporate Office
14402 Franklin Avenue
Tustin, CA 92780

Tel: (714) 832-9922
Fax: (714) 832-9924

For Technical Assistance:
(800) 638-0031

