

QUICK INSTALLATION GUIDE FOR PAIRGAIN™ TECHNOLOGIES HIGAIN™ REMOTE ENCLOSURE MODEL HRE-421 Issue 1

List 1 PairGain # 150-1125-01, CLEI: T1MFFB04RA
 List 2 PairGain # 150-1125-02, CLEI: T1MFFC04RA

CONTENTS	PAGE
A. PRODUCT OVERVIEW	
1. GENERAL	2
2. CERTIFICATION	2
3. WARRANTY	2
4. TECHNICAL ASSISTANCE	3
B. INSTALLATION	
5. LIST OF MATERIAL	3
6. MOUNTING	3
7. WIRING	3
8. TURN UP	4

CAUTION

This product incorporates static sensitive components.
 Proper electrostatic discharge procedures must be followed.

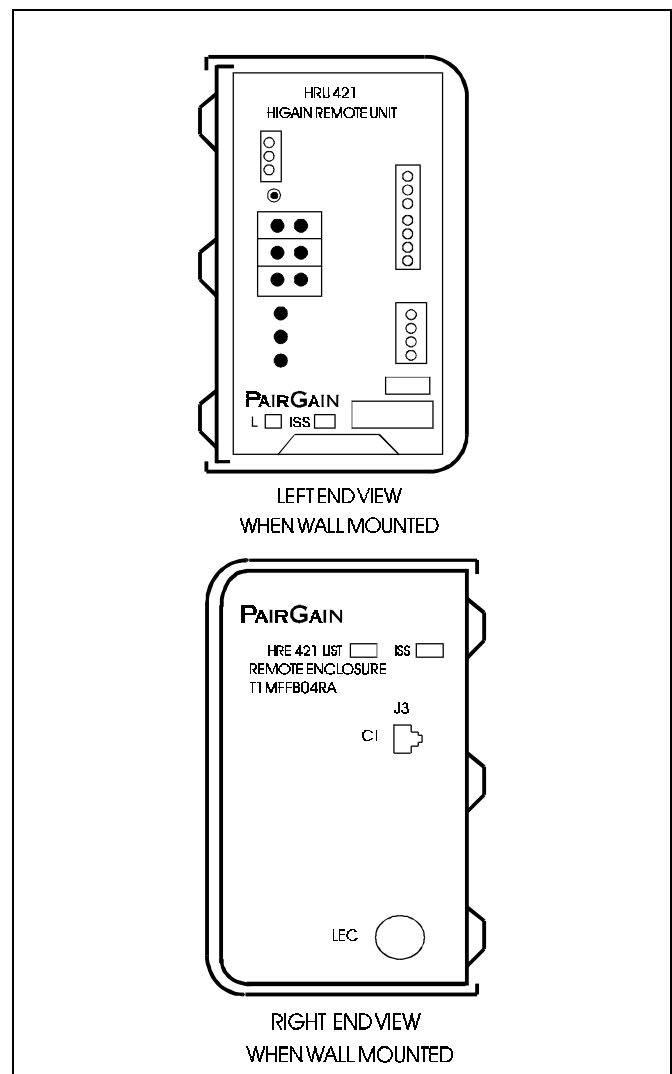

Figure 1. Left and right view of HRE 421, List 1 Enclosure.

Section 100-421-100
Revision 05

1. DESCRIPTION AND FEATURES

1.01 This Data Sheet describes installation of the HiGain HRE-421 Mounting Enclosure for HRU-412 Remote Units.

1.02 Revision—05, August 15, 1995

- a) Corrected CLEI Code and Part no.
- b) Revised document format.

1.03 This document is part of a set. Refer to the Description and Application Technical Practice #125-800-100 for additional information on the HiGain System and to #150-412-100 for information on the HRU-412 remote unit.

1.04 The PairGain HRE-421 shelf houses one HRU-412, has a Lexan front cover, and is wall or desk mountable. The unit consists of a wall mount section and a cover which slides over and is attached to the wall mount section. The wall mount section has the 400-type connector that accepts the HRU 412. It also contains a 14-position terminal block, TB1, for access to all interface signal connections, an RJ-48C (List 1) or RJ48X (List 2) connector for connecting DS1 leads and a DB9 RS-232 jack (J2) for telco access to the HIGAIN maintenance test system. A 2 position terminal block TB2, for access to local 48 V power and circuit ground, and a 48 V (1 amp) fuse are provided for the HRU-412, List 7 which can be locally powered. A rear panel punch-out labeled LEC (Local Exchange Carrier) provides cable routing to these inner connectors. The cover, which has the Lexan end plate, slides over the wall mounted section and is secured to it with a screw.

2. CERTIFICATION

2.01 UL Listing: The HRE-421 is a UL Listed component. Use normal caution when installing or modifying telephone lines. Dangerous voltages may be present. It is also considered imprudent to install telephone wiring during a lightning storm. Always disconnect all telephone lines and power connections from wall outlets before servicing or disassembling this equipment.

2.02 Refer to the installation section of the appropriate instruction manual for the unit you are installing for:

- Cabling information
- Proper connections
- Grounding information
- Line vs. local power

All wiring external to the product(s) should follow the provisions of the current edition of the National Electrical Code.

2.03 CSA Certification: The HRE-421 has been tested and found to comply with CSA Standard C22.2 -950 with telecommunication features.

3. WARRANTY

3.01 PairGain Technologies warrants this product to be free of defects and to be fully functional for a period of 36 months from the date of original shipment, given proper installation and regular maintenance. PairGain will repair or replace any unit without cost during this period if the unit is found to be defective for any reason other abuse or improper use or installation.

3.02 This module should not be field repaired. If it fails, replace it with another unit and return the faulty unit to PairGain for repair. Any modifications of the unit by anyone other than an authorized PairGain representative will void the warranty.

3.03 If a unit needs repair, call PairGain for a Return Material Authorization (RMA) number and return the defective unit, freight prepaid, along with a brief description of the problem, to:

PairGain Technologies, Inc.
14402 Franklin Avenue
Tustin, CA 92680
ATTN: Repair and Return Dept.
(714)-832-9922
(800) 638-0031

3.04 PairGain will continue to repair or replace faulty modules beyond the warranty program at a nominal charge. Contact your PairGain sales representative for details and pricing.

4. TECHNICAL ASSISTANCE

4.01 PairGain Technical Assistance is available 24-hours-a-day, 7-days-a-week by contracting PairGain's Customer Service Engineering group at one of the following numbers:

Telephone: (800) 638-0031
(714) 832-9922
Fax: (714) 832-9924

During normal business hours (8:00 AM to 5:00 PM, Pacific Time, Monday - Friday, excluding holidays), technical assistance calls are answered directly by a Customer Service Engineer. At other times, a request for technical assistance is handled by an on-duty Customer Service Engineer through a callback process. This process results in a callback within 30 minutes of initiating the request.

In addition, PairGain maintains a computer bulletin board system for obtaining current information on PairGain products, product troubleshooting tips and aids, accessing helpful utilities, and for posting requests or questions. This system is available 24-hours-a-day by calling (714) 730-3299. Transmission speeds up to 28.8 kbps are supported with a character format of 8-N-1.

5. LIST OF MATERIAL

5.01 The following material is included with each HRE-421:P

Description	Qty.
HRE-421 Technical Data Sheet	1
#10x3/8 pan hd. sht. metal screw	3
10-32x3/8 button tamper proof screw	1
Circuit Assignment Label	1

The tamper proof screw can replace the factory provided blade "securing screw" shown in Fig 2. This screw requires an Allen key wrench, available on request, to install. It is intended to provide additional security if desired. The gummed Circuit Assignment Label is for circuit I.D. It can be attached to any convenient location on the enclosure.

6. MOUNTING

6.01 See Figures 1 and 2. Select a location for wall mounting the unit which will allow sufficient access to wiring connections on the right and indicators, test jacks, etc., on the left. Lift the cover off the mounting plate and use it as a template for drilling or locating mounting holes. Attach the plate securely to the wall.

7. WIRING

7.01 Power and Grounding: See Figure 4.

Attach earth ground to FRAME GND if local practice dictates. Terminals 3 & 8 of TB1 are connected to pins 7 & 8 (S & S1) respectively of J3 in Figures 5 & 6. They are used to terminate the shields from the two CPE DS1 pairs and are provided for DS1 shield continuity if desired. These terminals are not connected to either Circuit or Frame Ground, but may be wired to either if required. The -48 V battery connection to TB2 is only required when using an HRU-412 that is provisioned for local powering.

7.02 HDSL Connections: Refer to Figure 4.

Connect HDSL loop 1 T & R to pins 1 (H1 TIP) and 2 (H1 RING) respectively of TB1. Connect HDSL loop 2 T & R to pins 4 (H2 TIP 1) and 5 (H2 RING 1) respectively of TB1. Since the HDSL signals are bi-directional, they do not carry a "transmit" or "receive" designation. With reference to T1 terminology, however, Loop 1 is called the "receive pair" and Loop 2 the "transmit pair". Note that if these leads are reversed, a "CHREV" message is displayed in the ALARMS display field when viewing the HRU STATUS screen from a HIGAIN terminal interface port. This condition does not affect system operation but it should be corrected to avoid any confusion regarding the identities of the 2 HDSL loops. Note that this CHREV message does not appear on the HLU's status screen.

7.03 DS1 Connections to CI: The DS1 CPE interface ports may be connected to either the RJ-48C (Fig.5)/RJ-48X (Fig.6) jack (J3), located on the rear panel of the HRE-421, or directly to TB1. If TB1 is used, connect the DS1 output from the CPE to terminals 9 and 10. Connect the DS1 input to the CPE to terminals 6 and 7. Note if TB1 is used for the CPE access when using the List 2 HRE-421, the shorted pins in the RJ-48X jack J3 must be opened. This is accomplished by inserting a dummy RJ-48 plug into J3.

Section 100-421-100
Revision 05

7.04 Current feed jumpers: See Figure 4.

List 1 & 2 HRU Connections: When the List 1 or 2 HRU-412 is being inserted into the HRE-421, jumper TB1 terminals 11 through 14 as required by the service order to provide none, 23 mA or 60 mA current feed toward CPE over the DS1 leads.

List 3, 4, 6 and 7 HRU Connections: When the List 3, 4, 6 or 7 HRU-412 is being inserted into the HRE-421, TB1 is not required to set the CPE current. For these units the CPE simplex terminal must be left vacant. This allows switch S2 located on the card edge connector at the back of these units to set the current either 60 or 0 mA., as required by the service order.

7.05 RS-232 Connections: Connector J2 wiring is shown in Figure 7. J2 is configured as an RS-232 DTE port. TD and RD are the names assigned to the pins per this RS-232 standard. The signal on RD is

an input to HiGain. That on TD is an output from HiGain. The port requires only pins 2, 3 and 5 to be connected. Typical connections to both DB 9 and DB 25 DTE terminal connectors are shown in Figure 7. J2 provides access to a local diagnostic terminal.

8. TURN UP

8.01 Refer to the PairGain Technical Practice Section of the unit being installed 150-412-100 for complete instructions. The HRU card slides into the two card guides as shown in Figure 3. It should be seated firmly in the connector. Upon initial turn up, all LEDs will momentarily light. If all equipment is installed and working, and the DS1 signal is being transmitted, the system will cold start within about 15 seconds. No further action is required if all alarms clear.

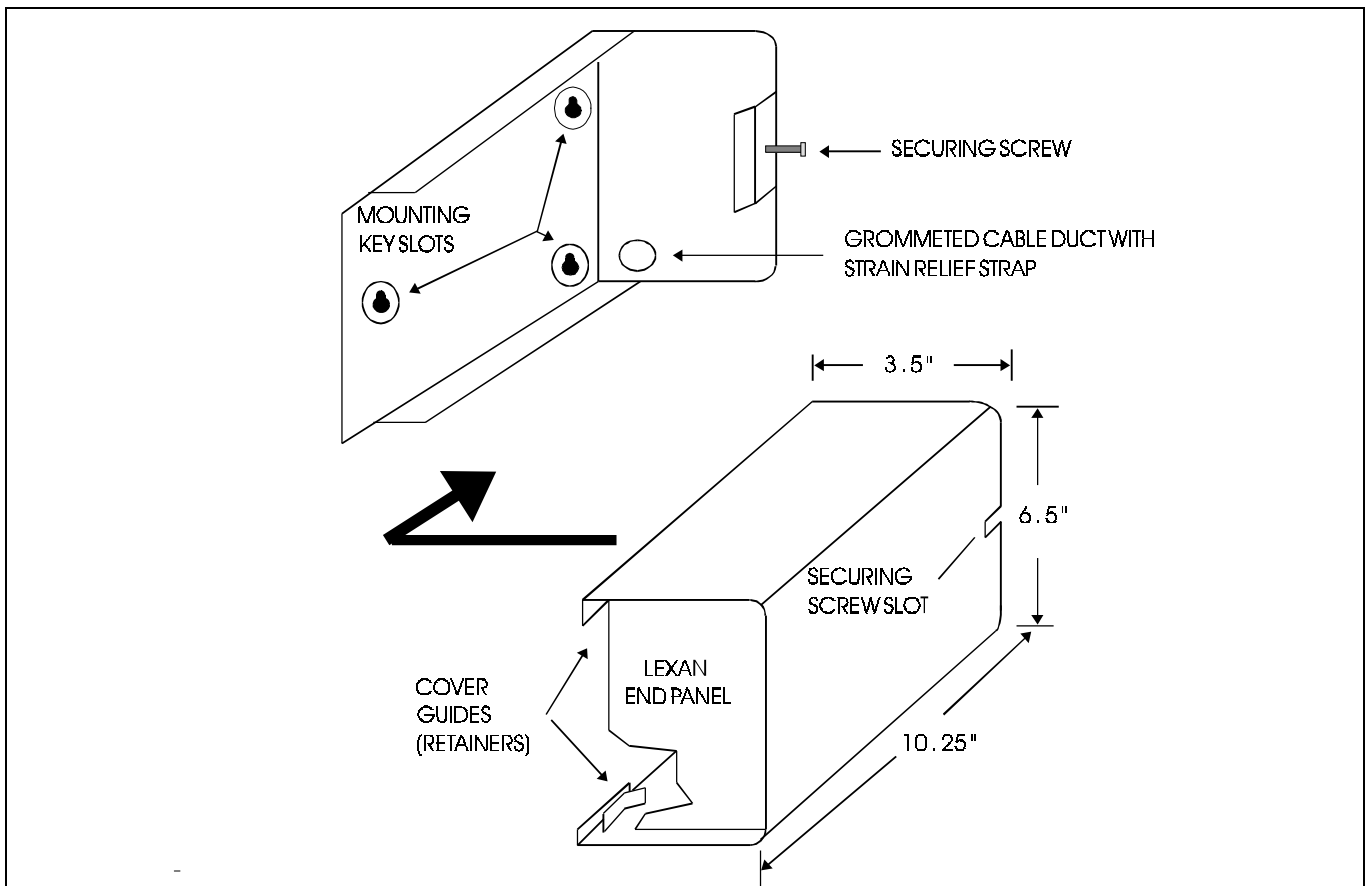

Figure 2. Wall Mounting.

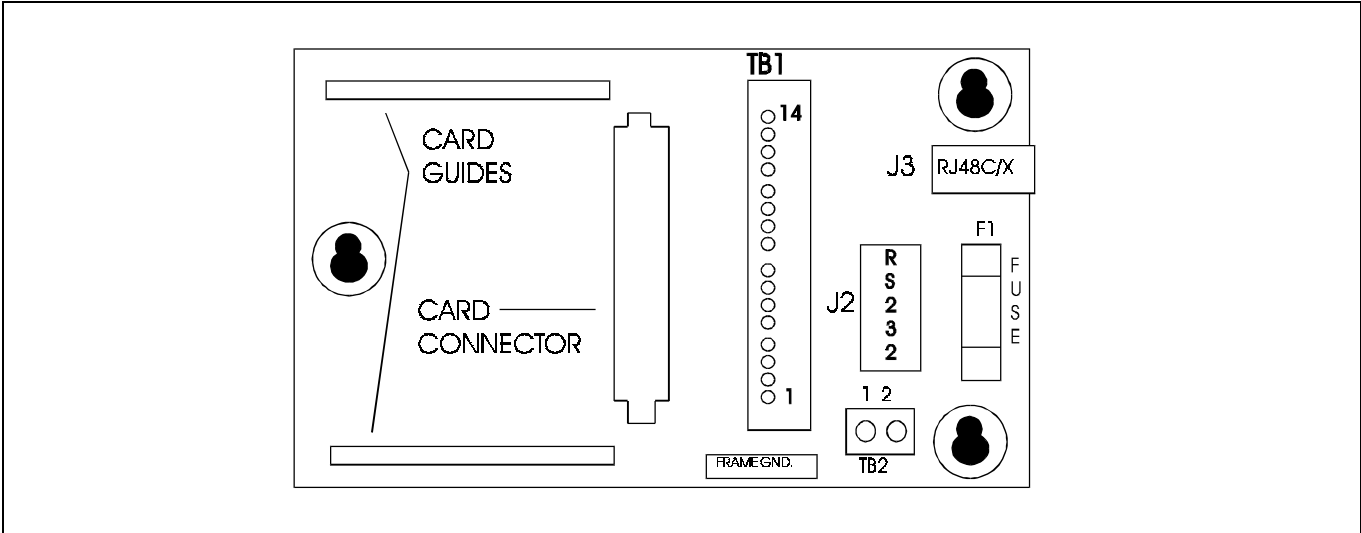

Figure 3. Component Locations.

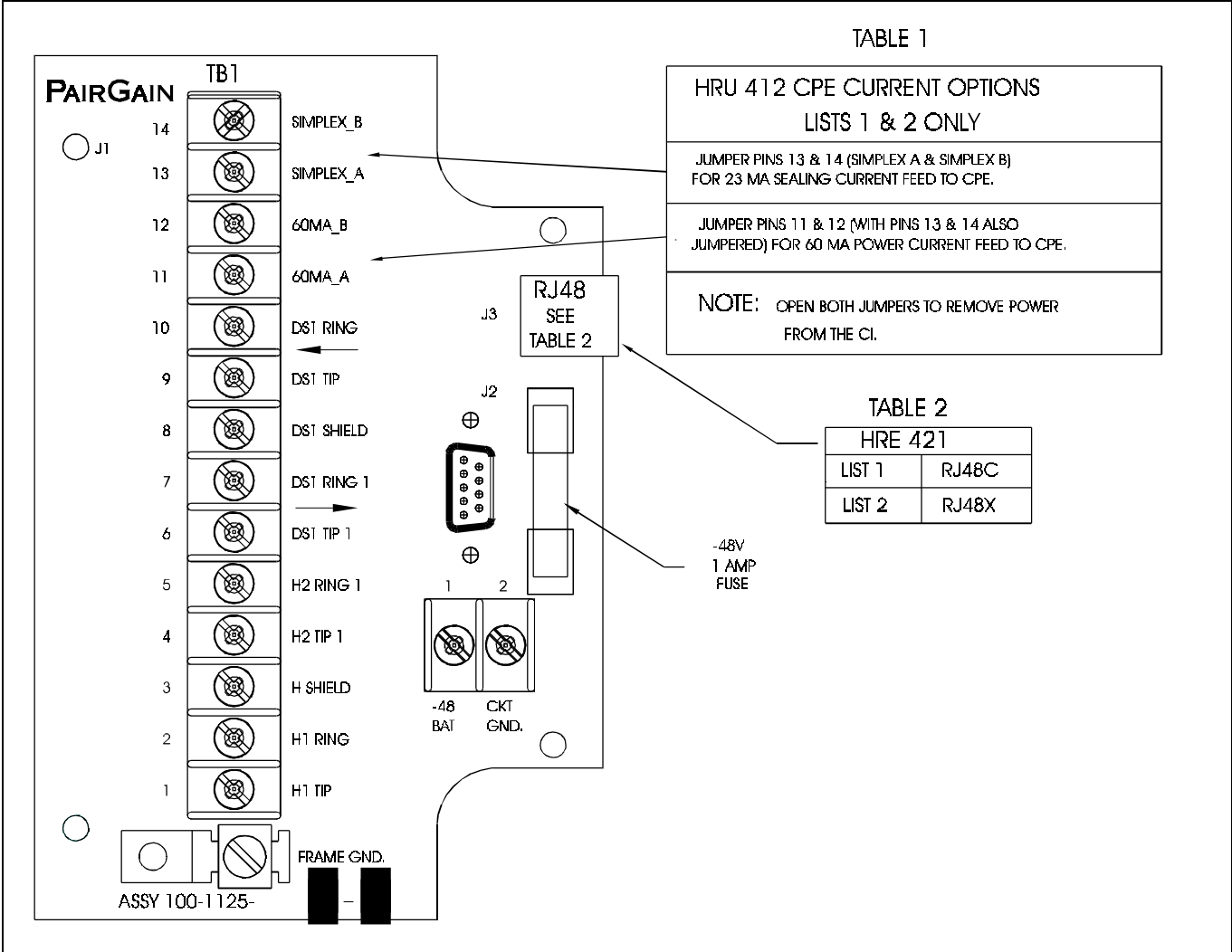

Figure 4. TB1 pin assignments.

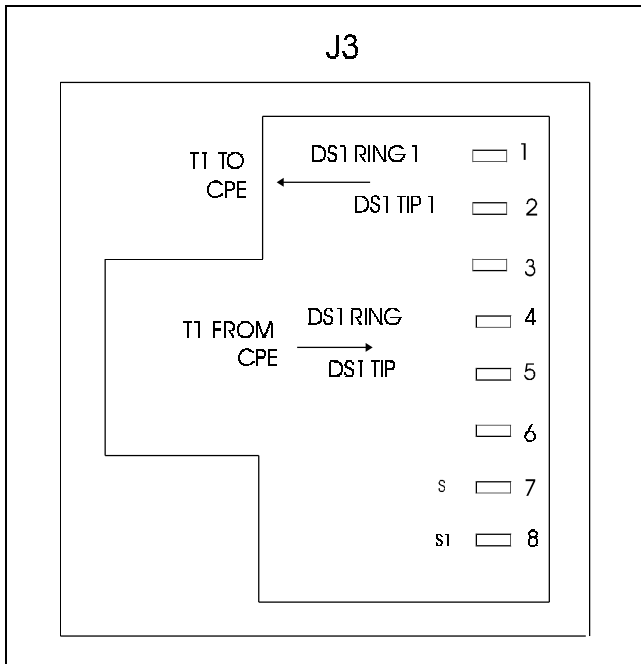

Figure 5. List 1 RJ-48C Pin Assignments.

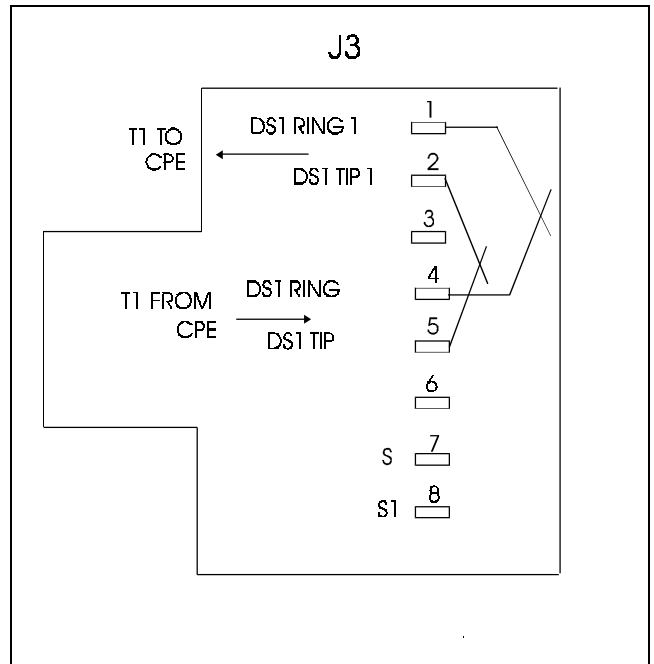

Figure 6. List 2 RJ-48x Pin Assignments.

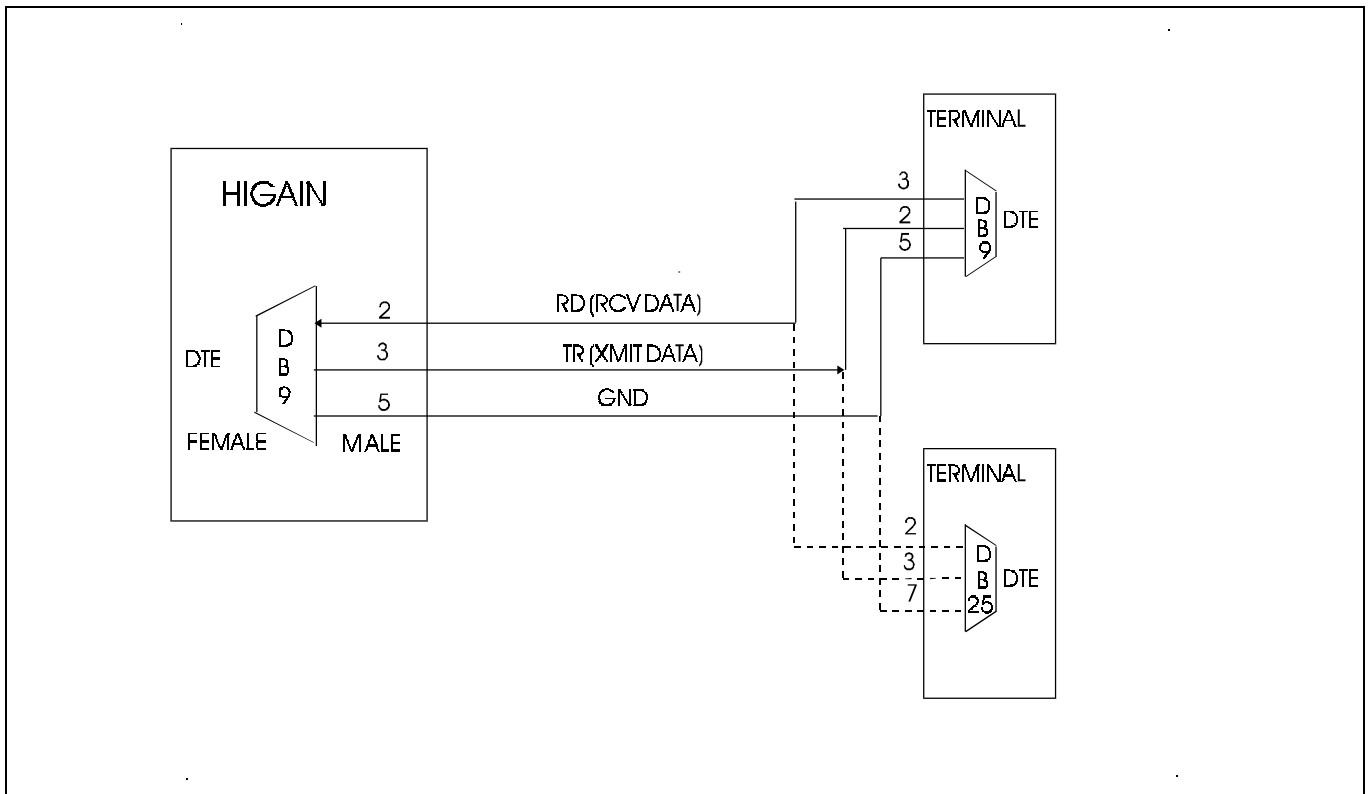

Figure 7. RS-232 Pin Assignments.